

## PRODUCT INFORMATION

### MOBILE SPEED ENFORCEMENT SENSOR

UMRR-11 Type 132

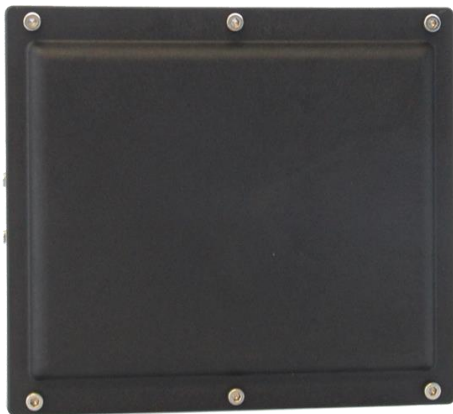

s.m.s, smart microwave sensors GmbH  
In den Waashainen 1  
38108 Braunschweig  
Germany

Phone: +49 531 39023-0  
Fax: +49 531 39023-599  
info@smartmicro.de  
www.smartmicro.com

## CONTENT

1	USER SAFETY WARNING .....	3
2	SENSOR SPECIFICATIONS.....	5
2.1	MEASUREMENT PRINCIPLE.....	5
2.2	SENSOR DIMENSIONS .....	8
2.3	SENSOR CONNECTOR.....	9
2.4	SENSOR AND HARDWARE IDENTIFICATION .....	10
3	GENERAL PERFORMANCE DATA.....	11
3.1	SELF-DIAGNOSIS.....	12
3.2	SENSOR NETWORK.....	12
3.3	ETHERNET CONNECTION .....	13
4	MOBILE SPEED ENFORCEMENT APPLICATIONS .....	14
4.1	EXAMPLE SITUATIONS .....	14
4.2	EGO VEHICLE SPEED REFERENCE.....	15
4.3	SENSOR MOUNTING POSITION .....	16
5	COMPLIANCES.....	17
6	LEGAL DISCLAIMER NOTICE .....	18

## 1 USER SAFETY WARNING

Please read the entire document carefully before using the sensor.

### INSTALLATION

Please pay attention to the details below before installing and connecting the sensor:

- Only use provided or approved equipment for the installation.
- Only skilled and instructed persons shall install and connect the sensor. Proper experience in working with mains voltage, electrical and electronic devices is required.
- Do not connect the sensor directly to the mains voltage; instead use the voltage specified for the product.
- Do not wire any connections when power is applied to the device.
- Ground devices carefully to prevent electrical shock.
- All connectors are pin-coded and fit in only one position. Also note the arrow indicating the top side of the sensor.
- Only use fully functional equipment (ladders, aerial work platform, etc.) when working above ground. Staff shall be capable of working at heights.
- Be cautious when installing the sensor on or around active roadways and pay attention to moving traffic.
- Mount the sensor carefully to prevent it from shifting or dropping.
- The sensor must be mounted to a stiff and solid support. Vibration, oscillation or other movement will reduce the sensor performance.
- Make sure that installation methods are in accordance with local safety policies and procedures as well as company practices.

### OPERATION

Do not operate the sensor if the device itself or any cables are damaged.

Transmission of radio frequency waves starts after the sensor is powered up and stops when it is disconnected from power.

For testing purposes, the sensor may be laid on its face when it is powered up, given that the surface or connectors will not be damaged this way. Please note that this position is not intended for permanent use.



The sensor may become hot during operation. Proper hand protection is recommended for maintenance work.



Do not dispose electrical and electronic equipment in household trash.

## TECHNICAL SERVICE

Only use provided or approved equipment for operation. People other than authorized and approved electrical technicians shall NOT attempt to connect the device to a power supply or other controllers, as there is a risk of electrical shock by unsafe handling of the power source.

Do not attempt to service or repair this device:

- No user-maintainable parts are contained in the device.
- To avoid electrical shock, do not remove or open the cover.
- Unauthorized opening will void all warranties.
- smartmicro is not liable for any damages or harms caused by unauthorized attempts to open or repair the device.

## RADIATION

This product has been tested and found to comply with Part 15 Subpart C of the Federal Communications Commission (FCC) or the European RED directive, or other national rules, depending on the country where it may be in use.

Operation is subject to the following two conditions:

- This device may not cause harmful interference.
- This device must accept any interference received, including interference that may cause undesired operation.

This device generates radio frequency energy. There are strict limits on continuous emission power levels to provide reasonable protection against harmful interference when the equipment is operated in a commercial environment.

- Human exposure to transmitted waves from this device is generally considered as safe. Still, it is considered good practice that humans are not subject to higher radiation levels than necessary.

This device may interfere with other devices using the same frequency band.

## 2 SENSOR SPECIFICATIONS

UMRR-11 Type 132 is a 77GHz radar sensor for multiple mobile speed enforcement related applications that features 4D/UHD technology.

Type 132 antenna aims at long range and wide horizontal angular coverage. It features:

- A wide beam mode with medium range
- A long-range mode with narrower field of view

### 2.1 MEASUREMENT PRINCIPLE

Using a patented transmit waveform, the sensor measures range, radial speed, azimuth and elevation angle, reflectivity and more parameters of multiple stationary and moving reflectors (targets) simultaneously. It is capable of ultra-high definition (4D/UHD), where UHD resolution means that the sensor features resolution (separation) in three parameters: range, Doppler and azimuth angle.

The sensor is almost unaffected by weather, temperature and lighting conditions. It withstands high shock and vibration levels, is maintenance free and made for a long lifetime.

### 4D/UHD MEASUREMENT

A 4D Doppler based radial motion detection principle is integrated:

- a) Direct unambiguous Doppler measurement (speed)
- b) Direct range measurement
- c) Direct azimuth angle measurement (horizontal angle)
- d) Direct elevation angle measurement (vertical angle)

Moving reflectors can be detected as well as stationary objects.

With its multi-target capability, the sensor can *detect* many reflectors within the field of view at a time (target list = point cloud). Additionally, optional filter algorithms are implemented for certain applications for the tracking of all detected reflectors over time. Those tracking algorithms are integrated in the sensor. Multiple objects can be *tracked* simultaneously.

The result of tracking is an object list with the following parameters:

- X-position
- Y-position
- Absolute velocity
- Heading angle
- Length
- Object ID and more

In addition, status and diagnose data from the sensor are reported. The sensor optionally reports such a list of all tracked objects in every measurement cycle of typically ~55ms length.

### **ULTRA-HIGH DEFINITION RESOLUTION - OBJECT SEPARATION PERFORMANCE**

The sensor divides the field of view into range gates and performs a Doppler (speed) measurement separate for each individual range gate.

Individual reflectors are separated by detection algorithms if having either:

- A different radial speed value or
- A different range value or
- A different azimuth angular position

### **USER CONFIGURABILITY**

The operational mode, antenna selection and frequency band are user-configurable:

The sensor allows to switch between medium-range mode and long-range mode. The modes differ regarding the waveform and the detection performance.

Simultaneously or independently, either narrow or wide beam operation can be chosen: The narrow beam mode can be selected for long range whereas the wide beam mode can be selected for medium range if needed. In typical use cases, however, the long-range mode always works with the narrow beam antenna, and the medium-range mode uses the wide beam antenna. The maximum range of the two modes is at bore sight.

The narrow beam mode can be used for applications like mobile speed enforcement at long range. The wide beam mode can be used for the same application but has a much wider field of view and a shorter range, which, however, is still high enough for most camera systems that are typically used to read license plates of the tracked vehicles (Automatic Number Plate Recognition, or ANPR) in the enforcement application.

For both modes, multiple non-overlapping frequency bands are available to reliably avoid mutual interference. Four frequency bands are available for long-range mode, two for medium-range mode.

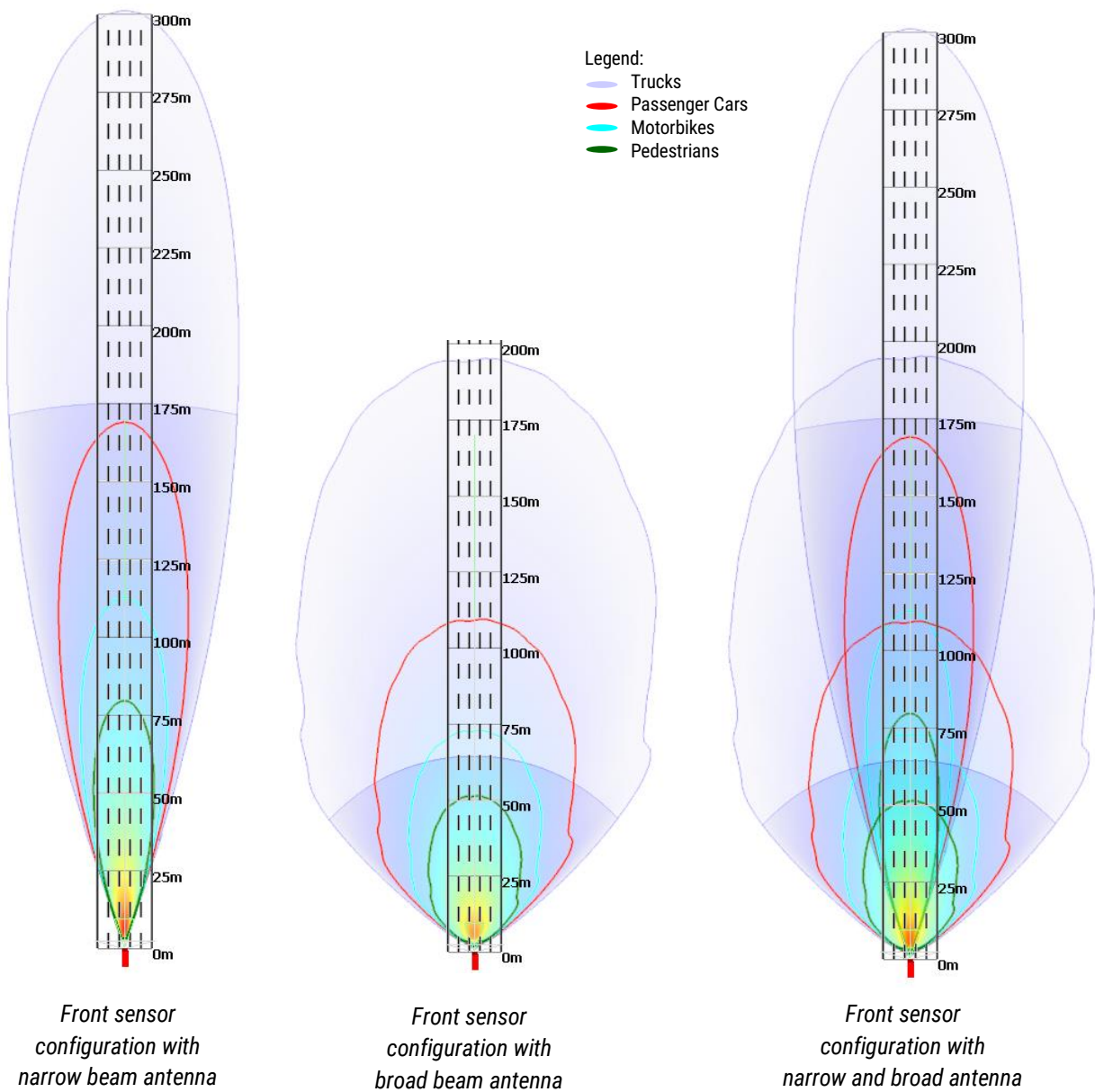

## 2.2 SENSOR DIMENSIONS

All values are given in mm.

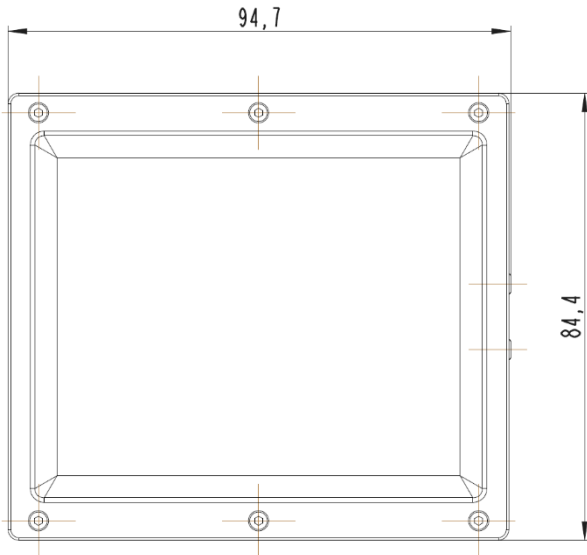

Sensor Front Side

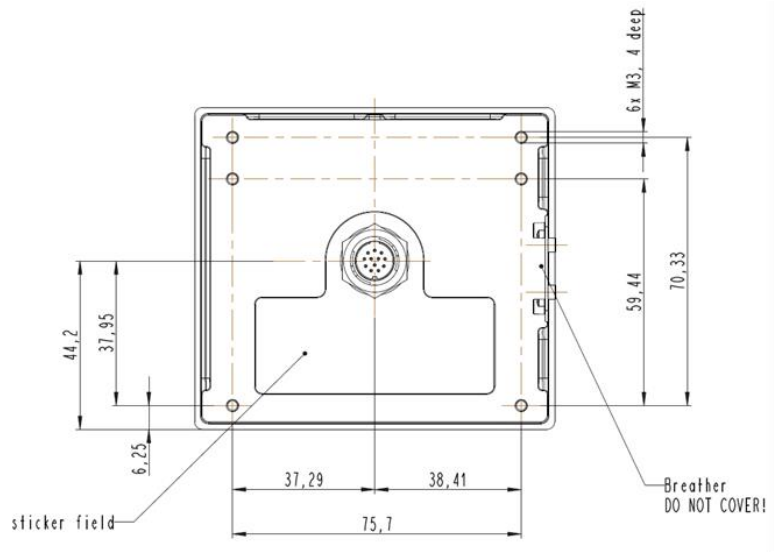

Sensor Rear Side

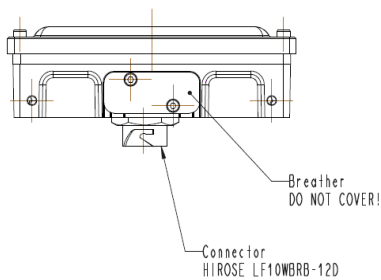

Left Side

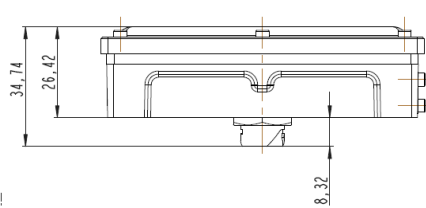

Top Side

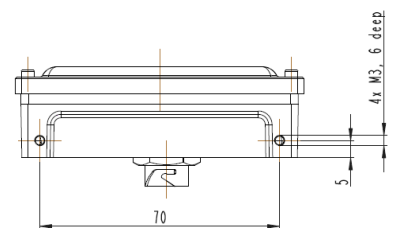

Right Side



### 2.3 SENSOR CONNECTOR

The sensor connector is a 12-pin male (plug) circular bayonet type connector (waterproof IP67, series LF10WBRB-12PD, manufacturer Hirose, Japan). A female counterpart (socket), e.g. LF10WBP-12S, must be used to connect with the sensor.

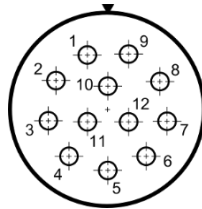

*View on solder cup side of socket showing the pin numbering  
(rear view of female counterpart to be connected to sensor)*

Sensor connector pin out model giving pin descriptions:

Pin No.	Function	Wire Color (MEDI type #KU110C12J002)
1	Sensor Ethernet TX H	Gray / red
2	Sensor Ethernet TX L	Red / blue
3	Sensor RS485 RX L	Pink
4	Sensor RS485 RX H	Gray
5	Sensor RS485 TX L	Brown
6	Sensor RS485 TX H	White
7	Sensor_GND	Blue
8	Sensor_Vcc	Red
9	Sensor Ethernet RX L	Black
10	Sensor Ethernet RX H	Purple
11	CAN H	Green
12	CAN L	Yellow

Please note that in the standard configuration the sensor does have a 120 Ohms resistor on board (CAN bus termination between CAN L and CAN H). Likewise, for the RS485 data interface there is a 120 Ohms resistor on board of the sensor.<sup>1</sup> This resistor is required at either end of a CAN / RS485 bus.

Several cable sets for initial operation and test purposes are offered by smartmicro, to deliver a fast set-up of a sensor system. Among those preconfigured ready-to-run cables as well as cable stumps (pig tail cables or various lengths) which carry the connector on one side and open wires on the other.

<sup>1</sup> RS485 interface is unused, the sensor can optionally be assembled for 2<sup>nd</sup> CAN(FD) bus.

## 2.4 SENSOR AND HARDWARE IDENTIFICATION

The sensor housing is tagged with a type sticker containing the product description and the serial number. It also indicates which side of the sensor is the top side.

Sticker example:

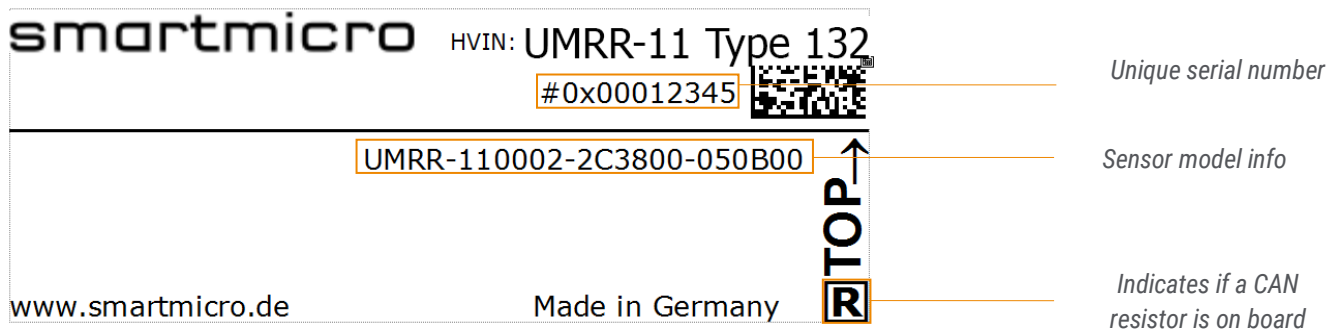

Additionally, the DSP board and the RF board have their own unique serial numbers.

### 3 GENERAL PERFORMANCE DATA

Parameter		Long-Range Mode	Medium-Range Mode
Operating Frequency		76...77GHz 4 center frequencies (bands)	76...77GHz 2 center frequencies (bands)
Range <sup>2</sup>	Min./Max. <sup>3</sup>	1.0m/175m   3ft/574ft	0.5m/64m   1.6ft/210ft
	Separation	≤ 1.8m   ≤ 5.9ft	< 0.66m   < 2.17ft
	Accuracy	< 0.5m   < 1.64ft or 1% (bigger of)	< 0.25m   < 0.82ft or 1% (bigger of)
Speed	Min./Max.	-400...+200km/h   -248...+124mph	-340...+170km/h   -211...+105mph
	Separation	< 0.26m/s	< 0.26m/s
	Accuracy	≤ 0.1m/s	< 0.1m/s
Angle	Field of View: Azimuth <sup>4</sup>	-16...+16° (narrow beam)	-50...+50° (wide beam)
	Field of View: Elevation <sup>4</sup>	-7.5...+7.5°	-7.5...+7.5°
	Separation: Azimuth	4° (optional)	15° (optional)
	Accuracy: Azimuth <sup>5</sup>	≤ 0.25°	≤ 0.5°
	Accuracy: Elevation <sup>5</sup>	≤ 0.5°	≤ 0.5°
<b>Mechanical Details</b>			
Weight		≤ 274g   ≤ 9.67oz	
Dimensions (H/W/D)		94.7 x 84.4 x 26.4mm   7.3 x 3.3 x 1in (plus connector)	
<b>Further Information</b>			
Initialization Time		< 10s	
Update Cycle Time		≤ 55ms	
Processing Latency		2-4 cycles	
Operating Voltage <sup>6</sup>		8...32V	
Power Consumption <sup>7</sup>		4.5...6W	
Bandwidth		< 1000MHz	
Max. Transmit Power (EIRP)		< 35dBm	
Operating & Storage Temperature		-40...+85°C   -40...+185°F	
Interfaces <sup>8</sup>		Ethernet 100Mbit (4-wire); 1xCAN V2.0b (passive)	
Connector		Hirose LF10 series	
Shock / Vibration		100g <sub>rms</sub> / 14g <sub>rms</sub>	
Relative Humidity		0...95% (non-condensing)	
IP		67	
Pressure or Transport Altitude		0...10000m   0...32800ft	

<sup>2</sup> Optionally, the minimum range can be reduced for customer-specific needs that depend on local frequency regulations.

<sup>3</sup> Typical values; all values given for bore sight; they may vary depending on the clutter environment. Please note that the radar system can neither achieve a detection probability of 100% nor a false alarm rate equal to zero.

<sup>4</sup> The total field of view is an angle interval in which reflectors can be detected; 3dB field of view is narrower.

<sup>5</sup> Typical value; measured at target output level at bore sight, for a point reflector showing >23dB SNR. Error may increase towards larger angles. In addition to this angle error, angle may drift over temperature, typically -0.5deg to + 0.5deg over specified operation temperature interval. CAN FD (optional)

## START-UP TIME

After powering up or resetting, sensor readings meet the specified performance in <10s.

### 3.1 SELF-DIAGNOSIS

The sensor cyclically reports a status message providing its cycle time, run time and diagnosis information. Additionally, the sensor can also provide sensor mode and status information on request.

The diagnosis information provided by the sensor is an optional self-diagnosis feature to allow limited fail-safe capabilities, which helps in detecting for example:

- Sensor blindness
- Rain
- Misalignment in roll or pitch angle
- Detection and suppression of interference

### 3.2 SENSOR NETWORK

Sensors are typically used standalone. However, for one vehicle up to four sensors can be connected to one sensor fusion ECU. Such networks are possible by using a CAN/CAN(FD) or Ethernet interface. All sensors in the network can work on a plug-and-play basis after the configuration of separate frequency channels, which avoid mutual interference. Customer-specific configurations are possible.

## DATA LOGGING AND VISUALIZATION TOOLS

The visualization of all data (target lists, object lists, etc.) is possible using the Drive Recorder software on any PC. It also provides for example data logging, associated video documentation, play back and analysis functions.

smartmicro offers Robot Operating System (ROS) support which includes ROS drivers for easier customer integration of the sensors and ready-to-run real-time visualization using ROS display tools. The proprietary radar protocol can be read into ROS, which facilitates the processing and visualization of radar data.

Alternatively to the Drive Recorder or ROS-based visualization, other customer specific visualization, logging, or function/application software products may be applied. For the handling and integration of the radar system interface, interface documentation, dbc files, example code (in C) and API can be provided.

<sup>6</sup> Measured at the connector.

<sup>7</sup> Depending on supply voltage and temperature; power consumption increases with supply voltage and with temperature.

<sup>8</sup> It is recommended to use an external surge protection for power, CAN, RS485, Ethernet and other interface ports.

### 3.3 ETHERNET CONNECTION

The sensor supports UDP via Ethernet in a Local Area Network (LAN). Communication over low bandwidth environments or routed networks such as the world wide web are not supported.

Features:

- Ethernet standards IPv4, ARP, IGMP, IP multicast and UDP
- Support of DHCP
- smartmicro's proprietary communication protocol "smartmicro transport protocol" with:
  - o IP/UDP Multicast based discovery protocol
  - o Client ID based setup
  - o Sensor data transmission

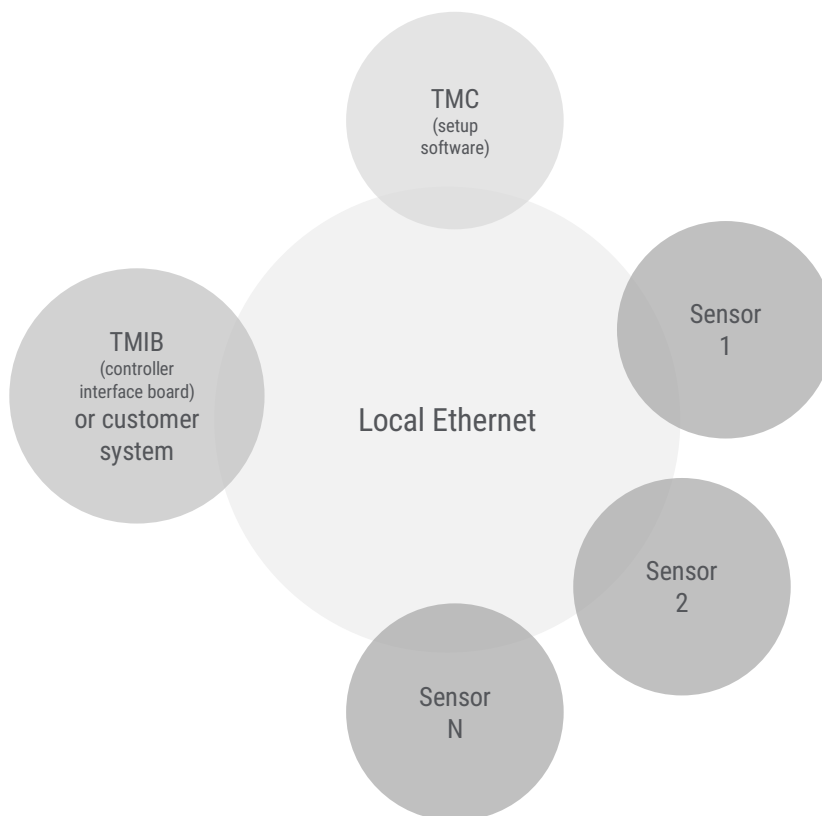

## 4 MOBILE SPEED ENFORCEMENT APPLICATIONS

The sensor can be used for mobile speed enforcement applications. A mobile speed enforcement system typically consists of an enforcement vehicle equipped with a smartmicro radar sensor, a video camera, a computing device and a speed reference.

Possible setup for mobile speed enforcement

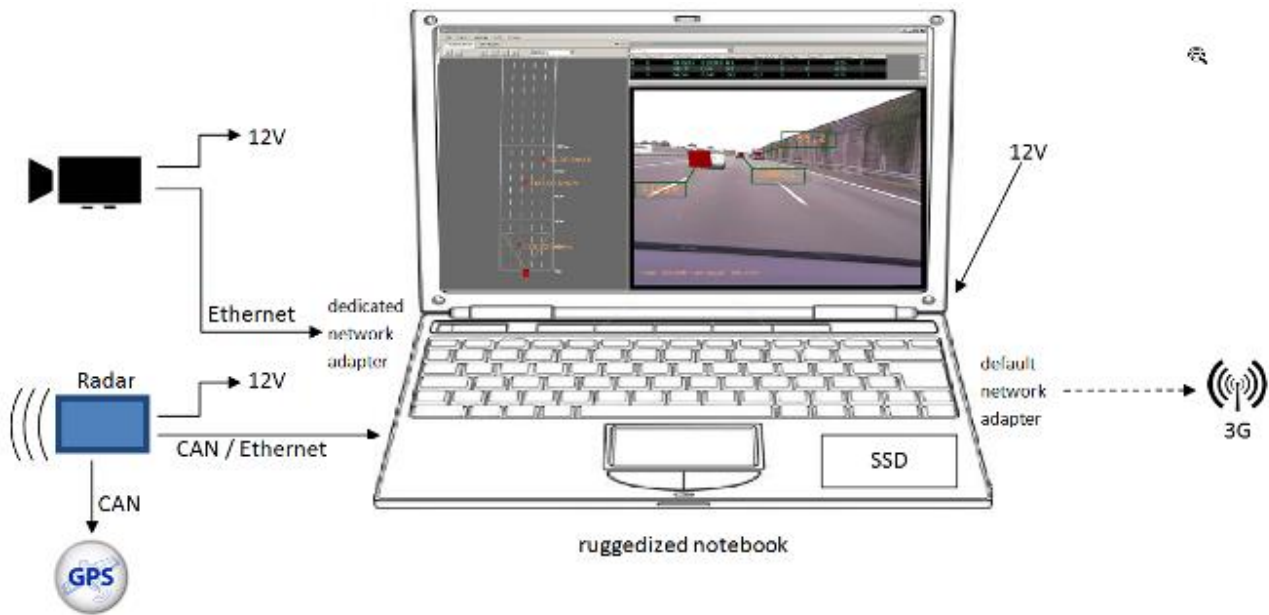

### 4.1 EXAMPLE SITUATIONS

The mobile speed enforcement functionality is available for both stationary and moving vehicle scenarios. The sensor tracks all traffic objects going in the same direction as the enforcement vehicle. Oncoming traffic objects can be tracked at the same time as long as there is no occlusion in between.

By configuration it is possible to report the absolute or relative speed of the detected vehicles.

## 4.2 EGO VEHICLE SPEED REFERENCE

The mobile speed enforcement vehicle needs its own speed, also called EGO speed, as a speed reference for correct operation of the vehicle tracking algorithms.

### BUILT-IN EGO SPEED REFERENCE

By default, the sensor determines the speed information by itself, typically by measuring the speed of stationary objects, without any external speed reference inputs.

### GPS EGO SPEED REFERENCE

A GPS sensor can optionally be used as an external source for the own speed value of the enforcement car. Such a sensor also provides exact position and date/time information. The connection between UMRR-11 Type 132 and a GPS sensor can be realized using the CAN interface of the sensor.

Supported GPS sensor:

- VBSS 10 by Racelogic, Inc. ([www.racelogic.co.uk](http://www.racelogic.co.uk))

### OBD-II

The radar sensor can optionally be connected to the OBD-II interface of the enforcement vehicle to read the EGO speed information. This connection can be realized using the CAN interface of the sensor.

Please note that only non-extended OBD-II CAN protocols are supported.

### 4.3 SENSOR MOUNTING POSITION

There are almost no restrictions on the type of car to be used for mobile speed enforcement, except that it should allow for the sensor to be mounted at a height of 0.4 to 0.8m above ground for best performance. However, it is possible to install the sensor on maximum height of 2m, for example in a “bar” on the roof of the vehicle.

The sensor can be mounted on an enforcement vehicle as follows:

- At the vehicle front
- Behind the bumper
- On the hood
- Behind the windshield



*Sensor mounted in front of the air intake*



*Sensor mounted behind the bumper*



*Sensor mounted on top of the car*



## 5 COMPLIANCES

The sensor model complies with the following EU directives:

- RED 2014/53/EU
- RoHS 2011/65/EU
- EC 1907/2006 REACH

Applied Standards:

- Spectrum Usage:
  - o EN 301 091-1 V2.1.1
  - o EN 301 091-2 V2.1.1
- EMC:
  - o EN 301 489-1 V2.2.0
  - o EN 301 489-51 V2.1.0
- Health and Safety:
  - o EN 62311: 2008
  - o EN 62368-1: 2014 + AC: 2015

Regarding spectrum usage, this sensor model was tested and certified by independent test labs (formally approved by a test lab or notified body):

- EU RED directive
- FCC part 95M
- ISED RSS-251

This sensor model is also generally compliant with the following regional regulations (but may not be formally tested/approved):

- SRRC
- KCC
- MIIT
- NCC

**Note:** This statement of compliance means that the sensor allows operation compliant to the listed standards. However, not all standards are certified through test labs. Formal frequency approval or registration is not accomplished for all countries. In certain countries or regions, a customer-specific local frequency approval is reasonable. smartmicro supports customers throughout this process.

## 6 LEGAL DISCLAIMER NOTICE

All products, product specifications and data in this document may be subject to change without notice to improve reliability, function or otherwise.

Not all products and/or product features may be available in all countries and regions. For legal reasons features may be deleted from products or smartmicro may refuse to offer products. Statements, technical information and recommendations contained herein are believed to be accurate as of the stated date. smartmicro disclaims any and all liability for any errors, inaccuracies or incompleteness contained in this document or in any other disclosure relating to the product.

To the extent permitted by applicable law, smartmicro disclaims (i) any and all liability arising out of the application or use of the product or the data contained herein, (ii) any and all liability of damages exceeding direct damages, including - without limitation - indirect, consequential or incidental damages, and (iii) any and all implied warranties, including warranties of the suitability of the product for particular purposes.

Statements regarding the suitability of products for certain types of applications are based on smartmicro's knowledge of typical requirements that are often placed on smartmicro products in generic/general applications. Statements about the suitability of products for a particular/specific application, however, are not binding. It is the customer's/user's responsibility to validate that the product with the specifications described is suitable for use in the particular/specific application. Parameters and the performance of products may deviate from statements made herein due to particular/specific applications and/or surroundings. Therefore, it is important that the customer/user has thoroughly tested the products and has understood the performance and limitations of the products before installing them for final applications or before their commercialization. Although products are well optimized to be used for the intended applications stated, it must also be understood by the customer/user that the detection probability may not be 100% and that the false alarm rate may not be zero.

The information provided, relates only to the specifically designated product and may not be applicable when the product is used in combination with other materials or in any process not defined herein. All operating parameters, including typical parameters, must be validated for each application by the customer's/user's technical experts. Customers using or selling smartmicro products for use in an application which is not expressly indicated do so at their own risk.

This document does not expand or otherwise modify smartmicro's terms and conditions of purchase, including but not being limited to the warranty. Except as expressly indicated in writing by smartmicro, the products are not designed for use in medical, life-saving or life-sustaining applications or for any other application in which the failure of the product could result in personal injury or death.

No license, expressed or implied, by estoppel or otherwise, to any intellectual property rights is granted by this document or by any conduct of smartmicro. Product names and markings noted herein may be trademarks of their respective owners.

Please note that the application of the product may be subject to standards or other regulations that may vary from country to country. smartmicro does not guarantee that the use of products in the applications described herein will comply with such regulations in any country. It is the customer's/user's responsibility to ensure that the use and incorporation of products comply with regulatory requirements of their markets.

If any provision of this disclaimer is, or is found to be, void or unenforceable under applicable law, it will not affect the validity or enforceability of the other provisions of this disclaimer.