

DISTRIBUTED BY



madison
Technologies

KEEP MINING KEEP MOVING

Industrial Communication and Computing
Solutions for Mining Digitalization

MOXA

The mining industry is at yet another crossroads in its hundreds of years of history. To stay profitable amidst technology changes, the industry is embracing automation, unmanned operations, and decarbonization. At the same time, it must confront a multitude of internal and external challenges.

The Ever-changing Landscape in the Mining Industry

Internal Challenges

Changing terrains-
mining deeper underground,
digging farther into mountains

Changing conditions-
flooding, toxic gases, explosions,
mine collapses

Changing technologies-
automation, remote controlling,
decarbonization

External Challenges

Evolving cyberthreats-
As mining equipment gets
connected, cyberthreats are not
affecting IT only but also OT

Evolving energy diversity-
Embracing net zero calls for renewable
energy and more complex grid
management

Evolving mining commodity selection-
Fast deployment and adjustments to
absorb market fluctuations in mineral
demand

Embrace Changes with Advanced Automation Networks - Let Moxa Help Keep You Moving Forward.

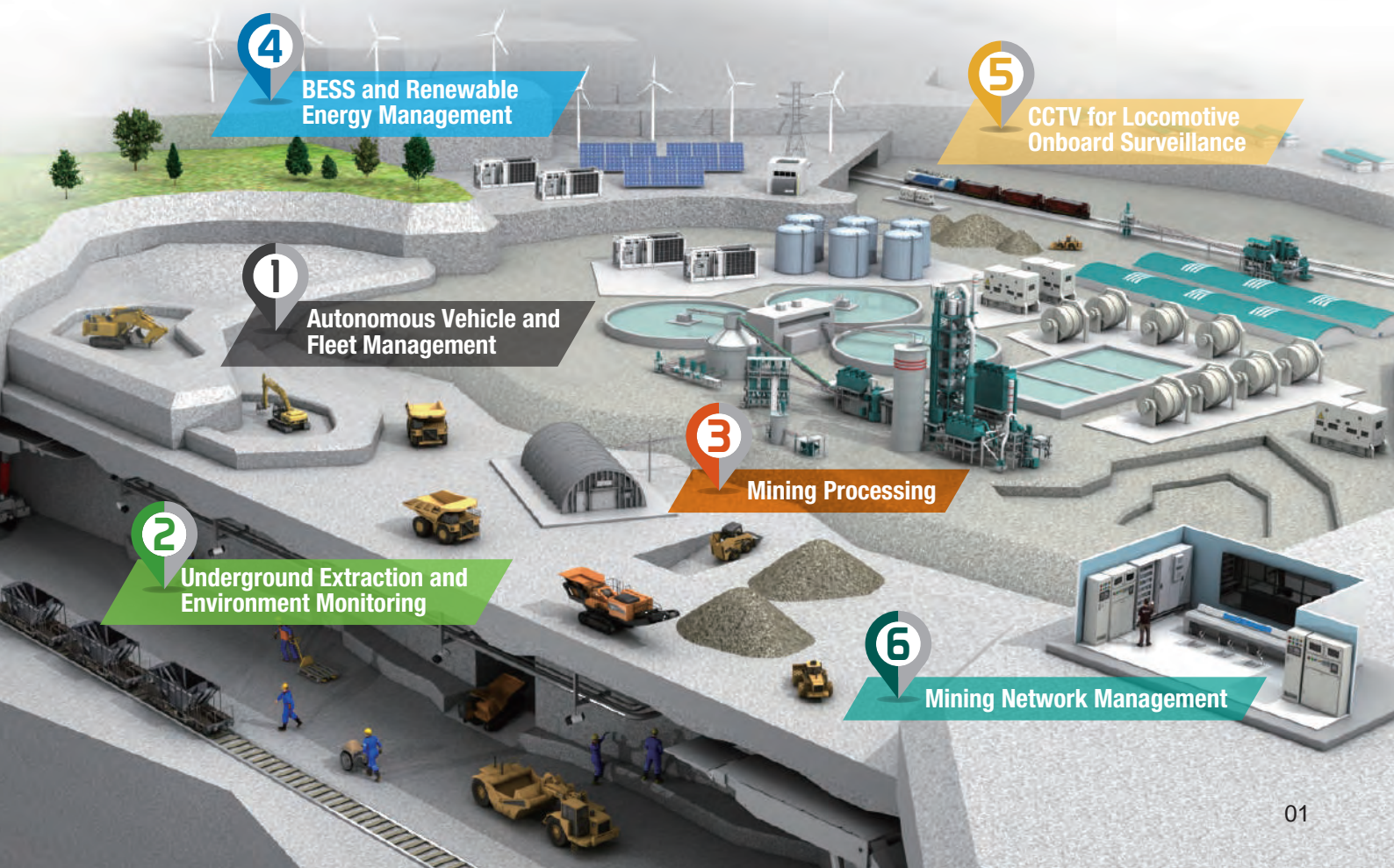

4

**BESS and Renewable
Energy Management**

5

**CCTV for Locomotive
Onboard Surveillance**

1

**Autonomous Vehicle and
Fleet Management**

3

Mining Processing

2

**Underground Extraction and
Environment Monitoring**

6

Mining Network Management

Moxa facilitates agile responses to diverse changes in the mining industry

Be Agile Today:

> Availability

From wired and wireless connectivity to high bandwidth, advanced redundancy, and roaming capabilities for industrial networks

> Visibility

Full visibility of wired and wireless devices from field sites to remote control centers

> Interoperability

Multiple protocols and edge computing fulfill OT/IT data convergence

Be Agile for the Future:

> Cybersecurity

Strengthen cybersecurity in OT networks and comply with IEC 62443 for IT/OT convergence

> Energy Diversity

From renewable energy, energy storage to smart grids and microgrids, we are experts in critical infrastructure, empowering sustainable and hybrid power supply through stable communication



Autonomous Vehicle and Fleet Management



Autonomous Mining Trucks

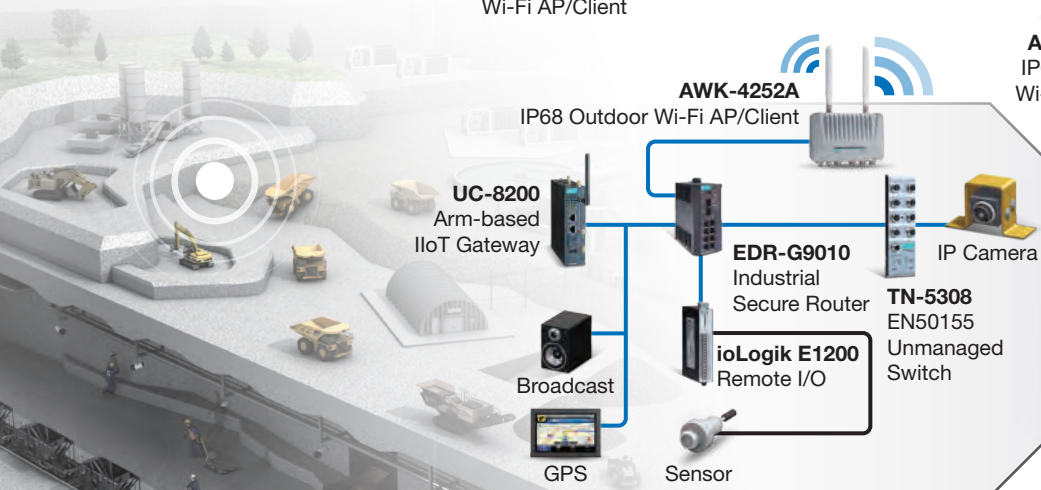
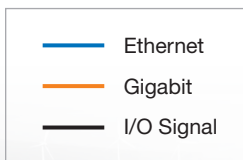
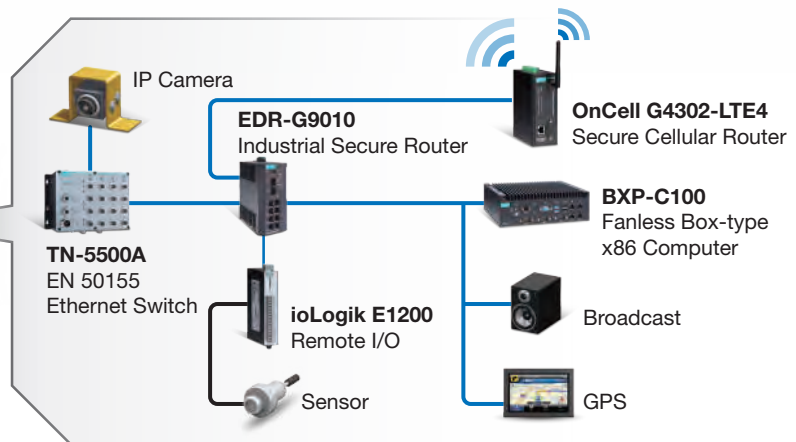

Underground Driverless Trucks



Robust Backbone Network for Underground Extraction and Environment Monitoring

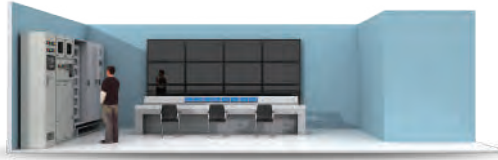
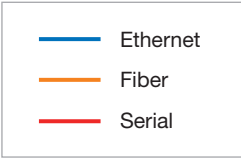

Remote Control Center

Tunnel Safety Monitoring System

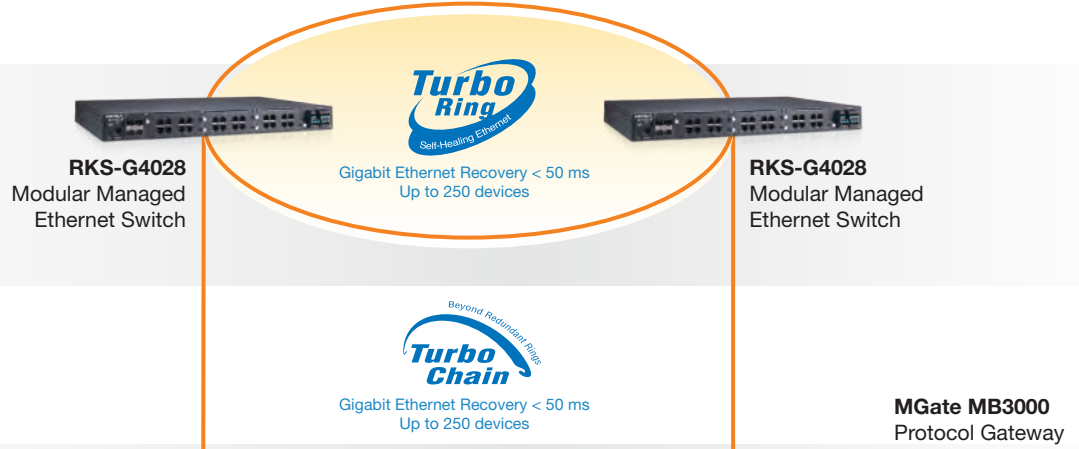

Underground Mining Extraction Monitoring

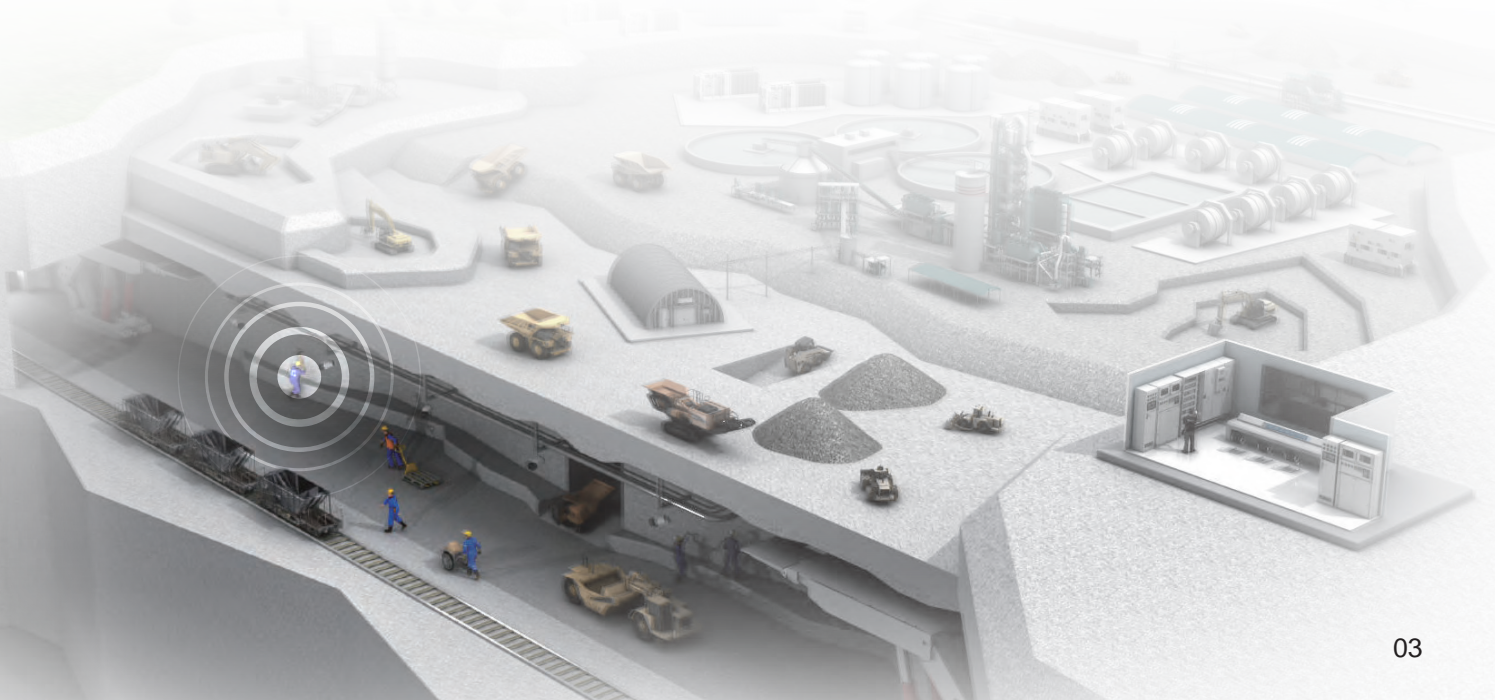
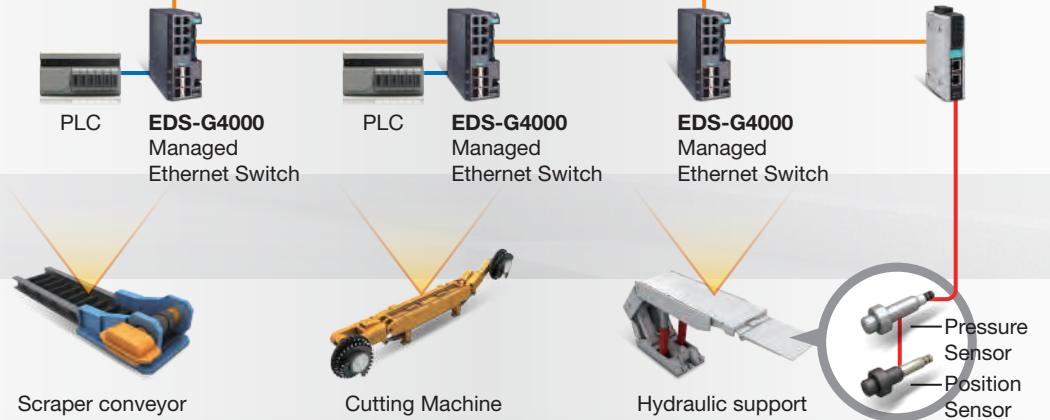



Processing Control System Networks

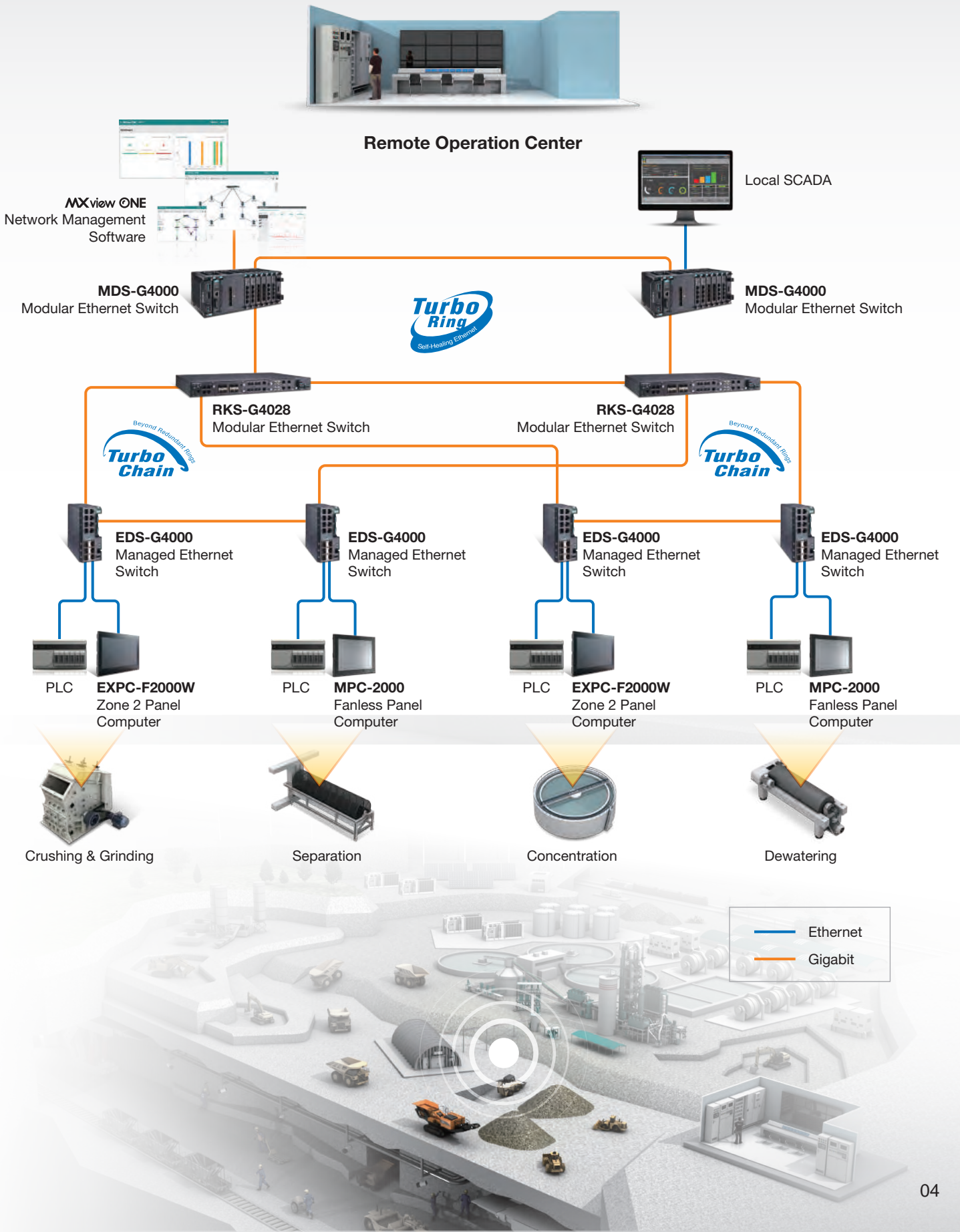

Moxa's Solutions for Grid-connected Battery Energy Storage Systems

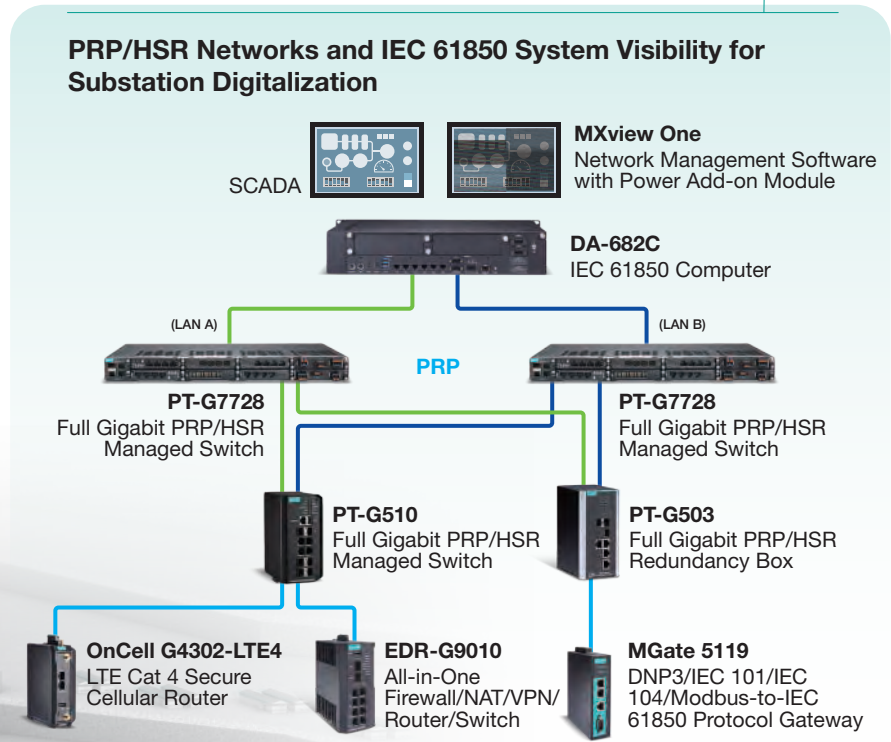
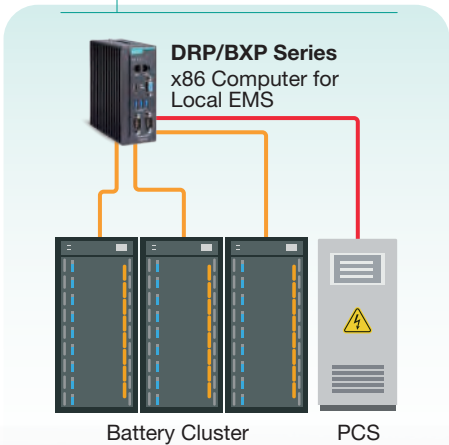
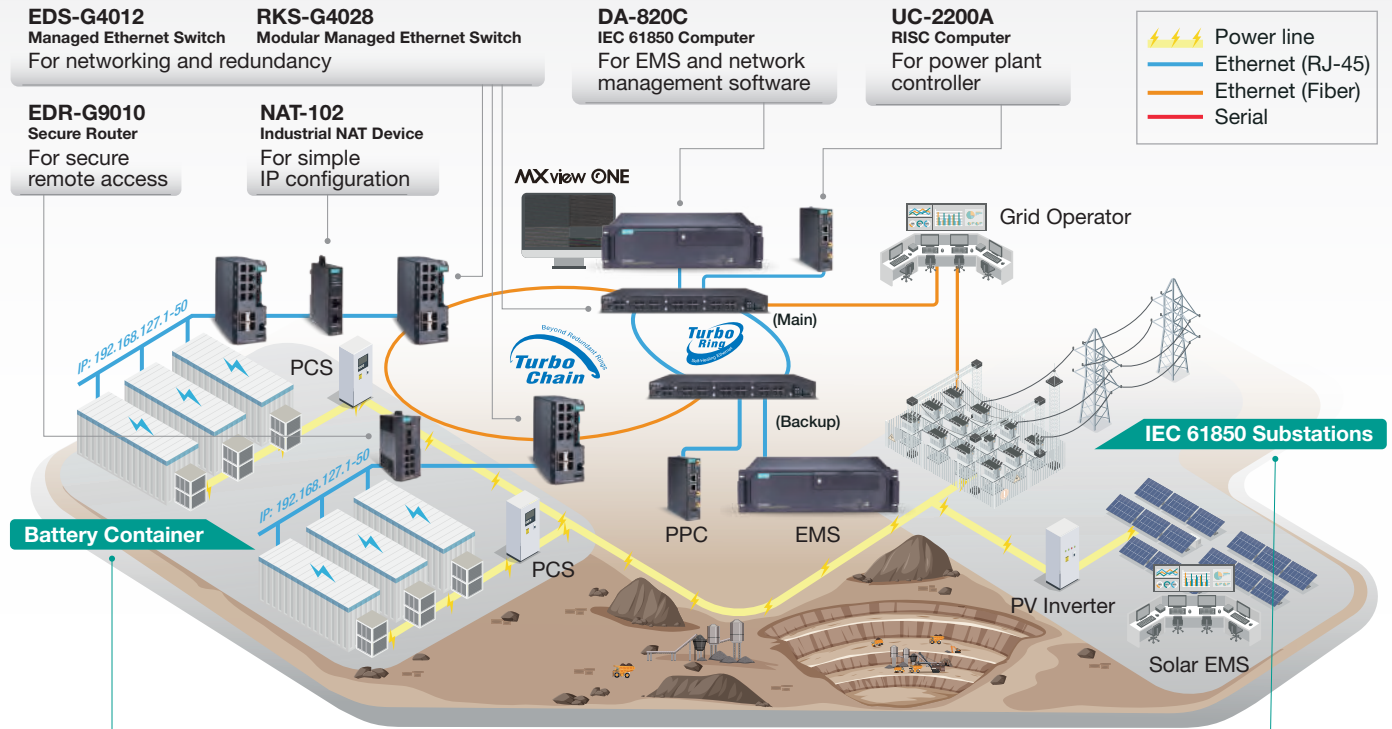

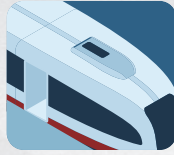

Forward-/Rear-facing Camera

VPort P16-1MP-M12
EN 50155 720P
Rugged IP Camera

Driver Cabin Camera

VPort P16-1MP-M12-IR
EN 50155 720P Infrared
IP Camera

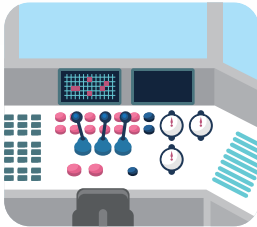
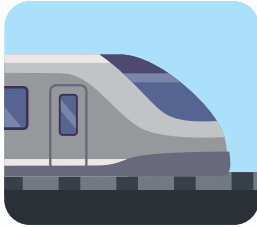

TN-G4500
EN 50155 M12 Gigabit
PoE Switch



MPC-2101/2121
EN 50155 10/12-inch
x86 Panel Computer



V2406C
EN 50155
x86 NVR Computer

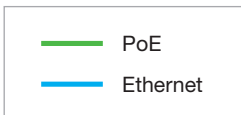

6 Mining Network Management

MXview One

Efficient Daily Operation



Network Status At a Glance



Flash Backup and Restore



Timely Notification



OT/IT Convergence Made Easy

MXsecurity

Enhanced Cybersecurity Protection



Firewall



IPS



DPI



VPN



NAT



Visibility on Malicious Activities



Unified Security Policy



Real-time Alert



Centralized Management



Operation Center



Your One-stop Shop: Addressing Diverse Connectivity Needs in One Go

Ethernet Switches/PoE Switches

Support Turbo Ring, Turbo Chain, STP/RSTP/MSTP for network redundancy, and provide PoE/PoE+/PoE++ options



Rackmount/Modular/ Din-rail Switches

RKS-G4028



MDS-G4000

EDS-4000/G4000



EN 50155 Switches

TN Series

IEC 61850 Switches

PT-G7728/G7828



PT-G510

Industrial Computers



Fanless x86 Computers NEW

11th Gen Intel® Core™ Processors

DRP-A100/C100

BXP-A100/C100

RKP-A110/C110



EN 50155 Certified

V2403C/2406C



IEC 61850 Certified

DA-820C/682C/681C

Fanless Panel PC NEW

Zone 2 Certified

MPC-3000

EXPC-F2000W



Industrial Wireless



Private 5G Cellular Gateways NEW

CCG-1500

Cellular Routers NEW

OnCell G4302-LTE4

Outdoor 802.3ac AP/Client

AWK-4252A



Secure Routers



All-in-One Firewall/NAT/VPN/Router/Switch

EDR-G9010

Industrial Network Address Translation (NAT) Devices

NAT-102



Industrial IoT Gateways

4G, MQTT, built-in device SDKs for Azure/AWS cloud, Moxa Industrial Linux 10-year support



Arm-based Computers

UC-5100/8200/2200A

AIG-101/301

Network Management



Network Management Software

MXview One with Power/Wireless Added-on Modules



Network Security Management Software

MXsecurity

Protocol Gateways



MGate MB3000

MGate 5000

Remote I/O



Modular/Standalone

ioThinX 4510

ioLogik E1200

IP Cameras



EN 50155 Certified

VPort Series

Your Trusted Partner in Automation

Moxa is a leading provider of edge connectivity, industrial computing, and network infrastructure solutions for enabling connectivity for the Industrial Internet of Things (IIoT). With over 35 years of industry experience, Moxa has connected more than 102 million devices worldwide and has a distribution and service network that reaches customers in more than 85 countries. Moxa delivers lasting business value by empowering industries with reliable networks and sincere service. Information about Moxa's solutions is available at www.moxa.com.



Book the Moxa Demo Ute for a free live demo of our mining solutions!

www.moxa.com/Demo-Ute ◀

MOXA®